



Engine Change Sling

The sling is designed to change CFM56-5A/-5B and V2500 engines on A320 family aircraft with or without inlet cowl / nozzle.

The engine is attached to three points, two at the fan case and one at the turbine case. The rear C-beam is rotatable to both sides to use the sling on left and right side engines. Also the engine can be rolled and moved, nose up and down. To use this sling an overhead crane is needed with slow drive speed and with a loading capacity corresponding to the engine types.



Engine Change Sling A320

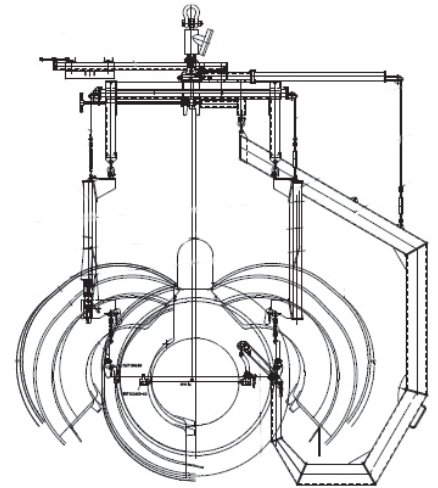

CUSTOMER ADVANTAGES

- customer performs engine change in one shift
- saves time and man hours
- convenient
- includes load indication system

Available for:

aircraft type	engine type
A300	CF6-80C2
A330	TRENT 700
A340	TRENT 500
A340	CFM56-5C
B737CL	CFM56-3
B747	CF6-80C2

Contact

Lufthansa LEOS GmbH
 Sales, Marketing & Product Development
 Lufthansa-Basis
 D-60546 Frankfurt/Main
 Germany

Hotline: +49-69-696-8222

Fax: +49-69-696-93888

Email: sales@lufthansa-leos.com

www.lufthansa-leos.com